

CAST Co., Ltd.



www.kkcast.co.jp

English version

PRIVACY PROTECTED

Shirakawa Factory



Description of Business

We manufacture and sell castings. Castings of FC (flaky graphite cast iron), FCD (spherical graphite cast iron), and alloy cast iron are manufactured semi-automatically and manually with a furan organic self-hardening cast molding process. The weight of handling is 50 to 4,000 kg, and the possible monthly production is 200 to 300 castings pieces per one type. The production items are mainly related to industrial robots, we are supplying frames for semiconductor mounting machines, machine frame, civil engineering and construction machinery, marine engine parts, truck axle parts and so on.

Greetings from Representative Director

Our company, CAST, was founded in Fukagawa, Tokyo in 1889. Since then, we have been favored by many customers as a casting company. On March of 1994, the entire factory was moved from Koto-ku, Tokyo to Shirakawa-shi, Fukushima.

In the Shirakawa factory, a work environment is realized in which the image of the conventional casting factory was entirely renovated so as to ensure 100% cleanliness and become a casting industry for the future. In order to meet our users' needs, we have cutting-edge facilities, and a system that can respond to a mass production of casting by manual molding.

In the casting industry, it is said that handing down the technique and skill is difficult. However, many young employees have been brought up well, and we are confident that we can be useful as a casting factory of a new age by combining our technique that we cultivated for many years with Information Technology. I wish you further prosperity.

Management Policies

AIM TO BE BEST

1. We steadily supply the best casting that meets our customers' needs at present and in the future.
2. We closely contact and contribute to the community.
3. We thoroughly perform environmental improvements inside and outside of the factory.
4. We aim at a healthy and culturally comfortable life.

Company Overview

Name of Company	CAST Co., Ltd.
Representative Director	Makoto Wakabayashi
Foundation	March 1889
URL	http://www.kkcast.co.jp/
Headquarters	27F Tokyo-sankei Bldg, 1-7-2 Ote-machi, Chiyoda-ku, Tokyo 135-0015 TEL 03-3242-6081
Shirakawa factory	2 Sasakubo, Higashikaminodejima, Shirakawa-shi, Fukushima 961-0302
Phone number	TEL 0248-34-3971 FAX 0248-34-3973
Factory site	Total area: 42,846 m ² Factory building: 3,960 m ² Office and others: 401 m ²
Capital	35,000,000 yen
Number of employees	40 employees
Description of business	Manufacturing and sales of normal cast iron, ductile cast iron, special cast iron, super high tensile strength cast iron, etc.

History

YEAR	MONTH	HISTORY
1889	March	The Sakai foundry was founded in Ofunaguramae-machi (currently Koto-ku, Tokyo).
1923	April	The Sakai heat-resistant metal foundry was established in Fukagawa Umibe-machi (currently Koto-ku, Tokyo).
1942	January	The company was reorganized to a joint-stock company, and became the Sakai Heat-resistant Metal Foundry.
1961	April	The company started sales of ductile cast iron.
1971	January	The Sakai Foundry Casting group (SFC) was organized and permitted due to the first foundry structure improvement projects (Ministry of International Trade and Industry).
1975	June	A high silicon cast iron HISILON 14 was completed. The company was approved by Tokyo small and medium-sized business product and upscale furtherance operations
1976	February	The super high tensile strength cast iron BD90 (90 to 110 kgf/mm ²) was developed and put on the market.
1985	September	An X-ray fluorescence spectrometer and an Amsler universal thermal expansion meter were introduced, and a quality assurance system (establishment of a quality assurance system group) was established.
1993	November	CI was introduced from the Sakai Heat Resistant Metal Foundry, and the name of the company was changed to CAST Co., Ltd.
1994	March	The Shirakawa factory (a structure improvement model factory) was completed. All facilities and analytical equipment were newly installed.
1995	October	The company was awarded "Forges and Foundries of Excellent Industrial Environment."
2001	August	The company entered the field of semiconductor implementation machines.
2002	June	The company entered the robotics field.
2004	March	The company was awarded a letter of appreciation from the Minister of Labor and Emigration of Republic of Indonesia due to the continuing operation of accepting trainees from Indonesia for over 10 years.
2007	March	"Intellectual Property Management Report" was created and disclosed based on the instruction from the Ministry of Economy, Trade and Industry.
	June	The company was selected and published in "3000 active small and medium-sized manufacturers in 2007." The company was entrusted with "Strategic Foundational Technology Improvement Support Operation of 2007."
2009	February	The company was selected to be "1,400 Employment Creation Companies."
	June	A small emission spectrophotometric analyzer, a black lead rounding rate measurement system, and a digital ultrasonic flaw detector were introduced.
2012	July	A restoration maintenance subsidy of group facilities, etc. for small and medium-sized businesses in Fukushima was approved.
	September	"SHIRAKAWA SOKEIZAI VALLEY" is composed of 10 companies dealing with metal in radius 20km distance. By using techniques such as casting, forging, die casting and more to create materials, and locally processing them including heat treatment, we will provide a stable feed of products for Japan and all over the world.
2013	November	"SHIRAKAWA SOKEIZAI VALLEY" won the encouragement prize for collaborative management of raw materials.
2015	June	"THE LEADING JAPAN FOUNDRIES" is a cutting-edge group to expand the global activities the purpose of which is aimed at the world market, to expand the sales network aggressively in that. This group "THE LEADING JAPAN FOUNDRIES" exhibited at "GIFA 2015".
2016	November	"SHIRAKAWA SOKEIZAI VALLEY" won the Nomura Prize of "New Tohoku Reconstruction Business Contest 2016".
	December	"SHIRAKAWA SOKEIZAI VALLEY" receives the 2nd Fukushima Industry Prize Special Award.
2017	March	Started selling original 「power blade」.
2018	March	"Vibrant HABATAKU Small and Medium Enterprises 300 and HABATAKU" and received the award.
	October	Indonesia trainee acceptance project With a continuation of 25 years, a letter of appreciation is awarded from the Labor Minister of the Republic of Indonesia

Shirakawa Factory – List of Main Equipment

A manual self-hardening process is considered to be one of the most difficult processes to simplify. However, the simplification is performed by standardizing while improving the productivity.

Category	Name of Equipment	Model, Capacity, and Number
Molding	Long arm mixer	20t / 30 t / hr 1 unit
	High speed mixer	5t / hr 1 unit
	Eco-mixer	5t / hr 1 unit
	Vibration table	3.5t / hr 1 unit
	Veneer automatic supply machine	1 unit
	Reverse extractor	3.5t / 1 unit
	Casting inverter	1.3t / 2 units
	Dash painting machine	4 sets
	Core inverter	2 units
	Paint drying furnace	1 set
Melting	High frequency induced electric furnace	1400kW 500Hz 2T 2 units
Sand treatment	Shake out machine with a hood	10t / hr 1 unit
	Sand treatment machine	10t / hr 1 set
Finishing	Crane type shot blast	5t 1 unit
	Batch type shot blast	0.5t 1 unit
Carrier	Semiautomatic molding cover line	1 set
	Crane	10t×2 units, 5t×3 units, 2.8t×7 units, Others
	Running truck	15t×1 truck, 10t×2 trucks, 7.5t(B)X 10 trucks, Others
Environment	Dust collector	600m ³ /min 1 set
		400m ³ /min 1 set
		200m ³ /min 1 set
	Ring hood and ladle hood	1 set
Central cleaner	1 set	
Inspection	Emission spectrometry analyzer (AMETEK)	SPECTRO MAXx-BT
	Molten metal component controller (NISSAB)	CE meter NSP-3601
	Molten metal component controller	CE meter KR526
	Immersing thermometer (NISSAB)	NSP-203R
	Metal microscope (OLYMPUS)	PME-3(x50·100·200·400)
	Black lead rounding rate measurement system (OLYMPUS)	analySIS FIVE
	Tensile tester (SHIMADZU)	UEH-50 (Metallic material universal tester)
	Brinell hardness tester (Maekawa Testing Machine MFG)	(φ10 3,000kg load)
	King Brinell hardness tester (Fuji Testing Machine)	(φ10 3,000kg load)
	Shore hardness tester (TAKES Group and Imai Seiki)	(Hs10 to 80)
	Ultrasonic flaw detector (Ryoden Shonan Electronics)	UI-25 (Digital ultrasonic flow detector)
Warehouse	Automated warehouse	147P 640 m ²
	Tent warehouse	495 m ²
	Tent warehouse	290 m ²
	External warehouse	166 m ²

Automated Warehouse



Molding



Reverse Extractor



Electric Furnace



Pouring



Inspection

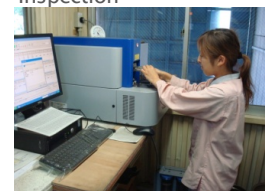

Sand Treatment



(1) Industrial Robot Related Products

A robot is active in all assembly steps of automobile parts (handling, spot welding, etc.). We manufacture a large amount of castings that are used in the arms, the main body, etc. of a robot. This casting has many cores, is generally thin, but the thickness partially varies. Therefore, a high level of technique is required.

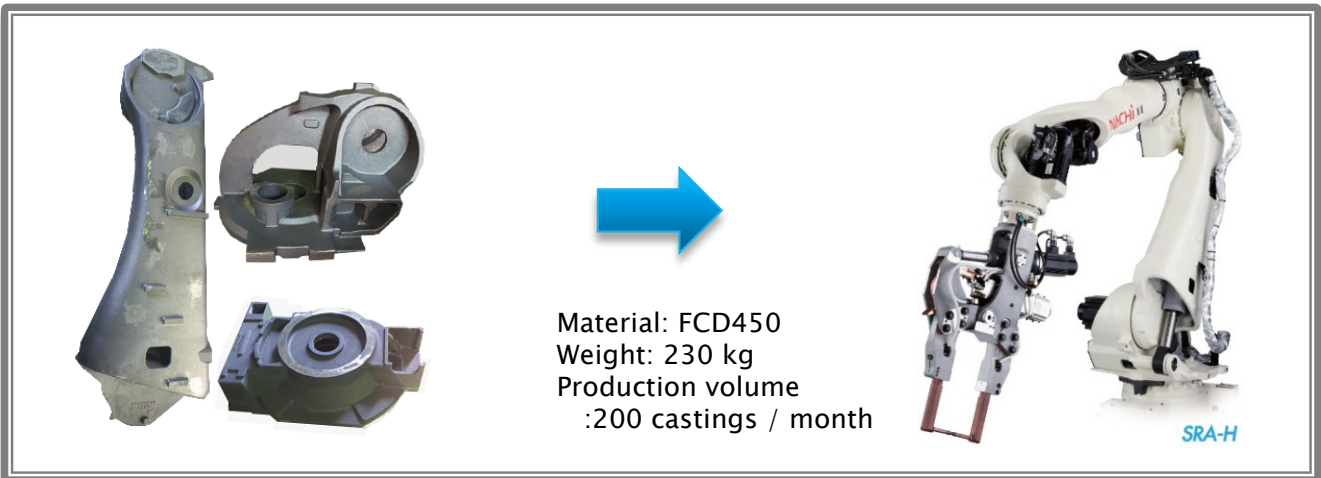

(2) Frame for a surface implementation machine and Machine tool frame

Printed circuit boards are inserted in household electric appliances such as a cell phone and a personal computer and auto industry products. Using a surface implementation machine, electronic parts such as IC's are loaded on the printed circuit boards. We manufacture a large amount of the frame that becomes a skeleton of such surface implementation machine. This casting has a complicated shape and is generally thin.

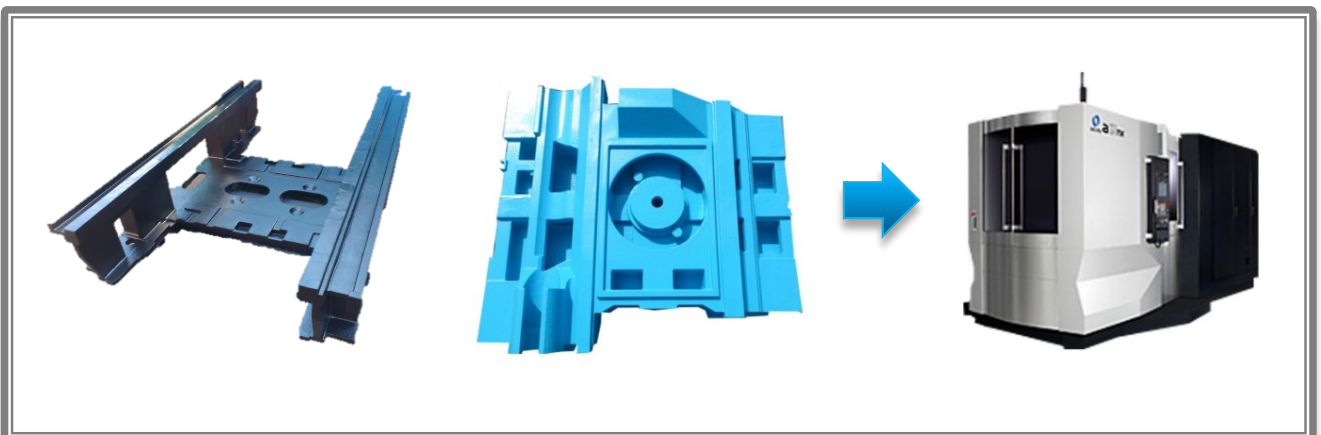

(3) Civil Engineering and Construction Related Products

A vibro compactor is a machine that presses and hardens (rolling compaction) rolling compaction soil, sands, asphalt, etc. It is used in construction of a walk way and a water pipe in which the area of the work is narrow. We manufacture a large amount of castings of most important rolling compaction parts. A high smoothness is necessary for the surface of this casting where it directly makes a contact with the ground, and a toughness is required because it is always vibrating.

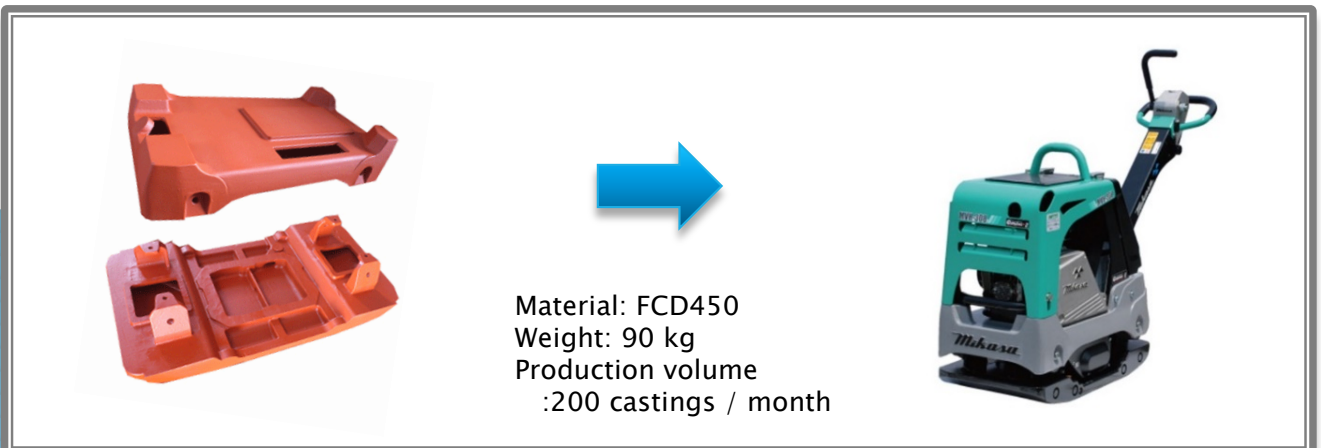

(4) Marine engine water-cooled exhaust manifold and lorry axle parts

The Water Jacket is set inside of the Exhaust Manifold by monolithic casting. This technology is intended to increase safety by minimizing exposure of high temperature parts in their limited engine room as well as improving the performance of the engine. Marine engine makers appreciate CAST's products for their engines parts with fine technology to manufacture complicated and compact casting parts with high quality.

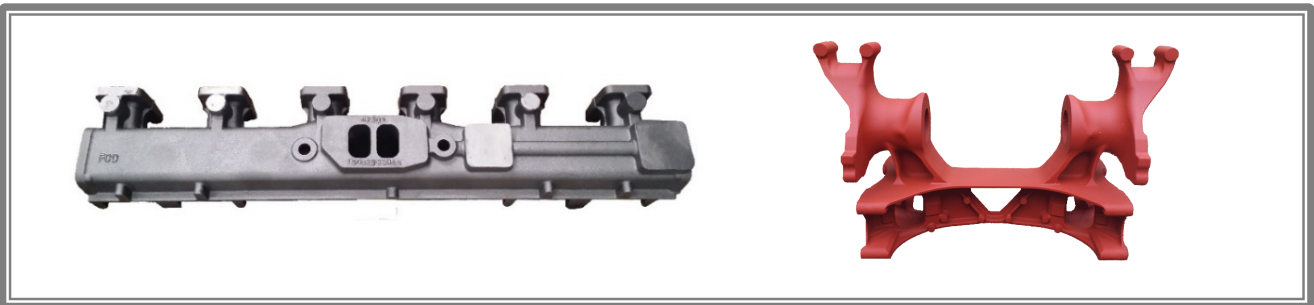

(5) Forklift Attachment "POWER BLADE"

You can use it as a dozer just by stabbing it with a nail of a forklift and fixing it with a ratchet. Developed our original products in 2017. It is made of 130-year-old casting shop seriously made first-class goods, an unified structure of commitment, and the craftsmanship glows casting products. We have also developed a large-sized blade that can handle interchangeable replacement blades and 5 ton forks, and increased lineup.



Strength of Business

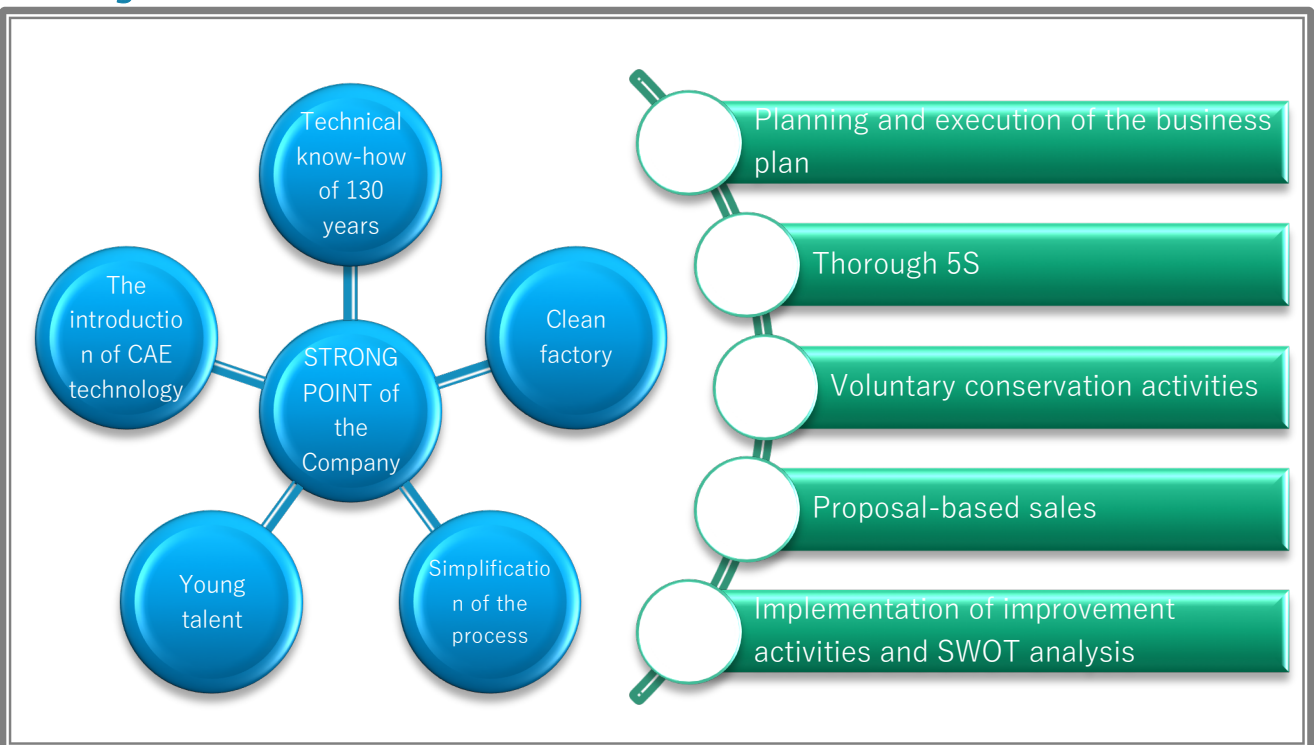

CAE technology

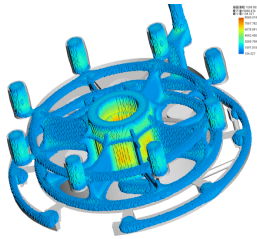

A technique that has been accumulated for a long time (130years)

A tacit knowledge (craftsmanship) is being replaced by an explicit knowledge. In the Tokyo factory, we received many orders of a single casting, and designing the casting method was an important factor to be successful in one try. The design of the casting method by hand calculation using “Modulus” exceeded 4000 pages, and it was stored by paper. However, all of the designs of the casting method written in paper were computerized and put in a database by introducing a technique of database software “Cast Navi” produced by Japan Casting Association, and it became possible to search the data for a design of a casting method, a casting history, a defect, etc. any time.

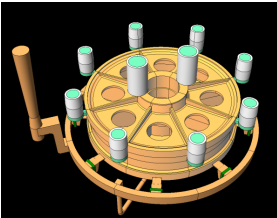

In 2010, a part in the casting that had been a black box has been visually made clear by introducing a metal flow and solidification simulation software. We propose to our user the design of casting at an early stage of development using the simulation software.

Safety Education



We holds a safety patrol and a safety meeting monthly mainly by the safety committee. Not only the employees, but also all of temporary workers and trainees from Indonesia are participating.

We patrol the factory, and create reports on dangerous areas, etc. The chairman introduces examples and reports a current status of improvement measures, and we continue this as a common recognition.

Personnel that CAST Recruits



We encourage young employees to participate in a casting college where we make a system in which people can acquire various techniques and study chemical explication such as “what is casting?” and promote personnel who become a core of CAST to acquire a certification of casting engineer. We look for active people who can participate in “making a thing” positively regardless of educational background, experience, and gender.

Shirakawa Factory

2 Sasakubo, Higashikaminodejima, Shirakawa-shi,
Fukushima 961-0302
TEL +81-248-34-3971 FAX +81-248-34-3973

Transportation	Distance
Tohoku Shinkansen	Tokyo to Shinshirakawa (1 hr 23 min) (outbound), Hachinohe to Shinshirakawa (about 3 hr) (in-bound)
Driving (from Tokyo)	About 24 km from Shirakawa Interchange of Tohoku Expressway
Driving (from Sendai)	About 18 km from Yabuki Interchange of Tohoku Expressway



CAST Co., Ltd.



www.kkcast.co.jp

English version