



# 製品紹介

Products Line



太洋マシナリー株式会社

TAIYO MACHINERY CO., LTD.

URL : <http://www.omco-taiyo.co.jp>

# Giving innovations to the world!!

— Pioneer of the future —

Starting our career in 1927 as the Japanese first manufacturer of foundry equipment and products, we have done our best to contribute to the development of the industry and the industrial society for more than 80 years. We owe the prosperity of this business to your support and really appreciate it. With our own technology and positive development, we have been awarded as one of the leading companies in this field of industry both in Japan and in the world. However, we will never content ourselves with the present position and continue striving to widely contribute to the society.

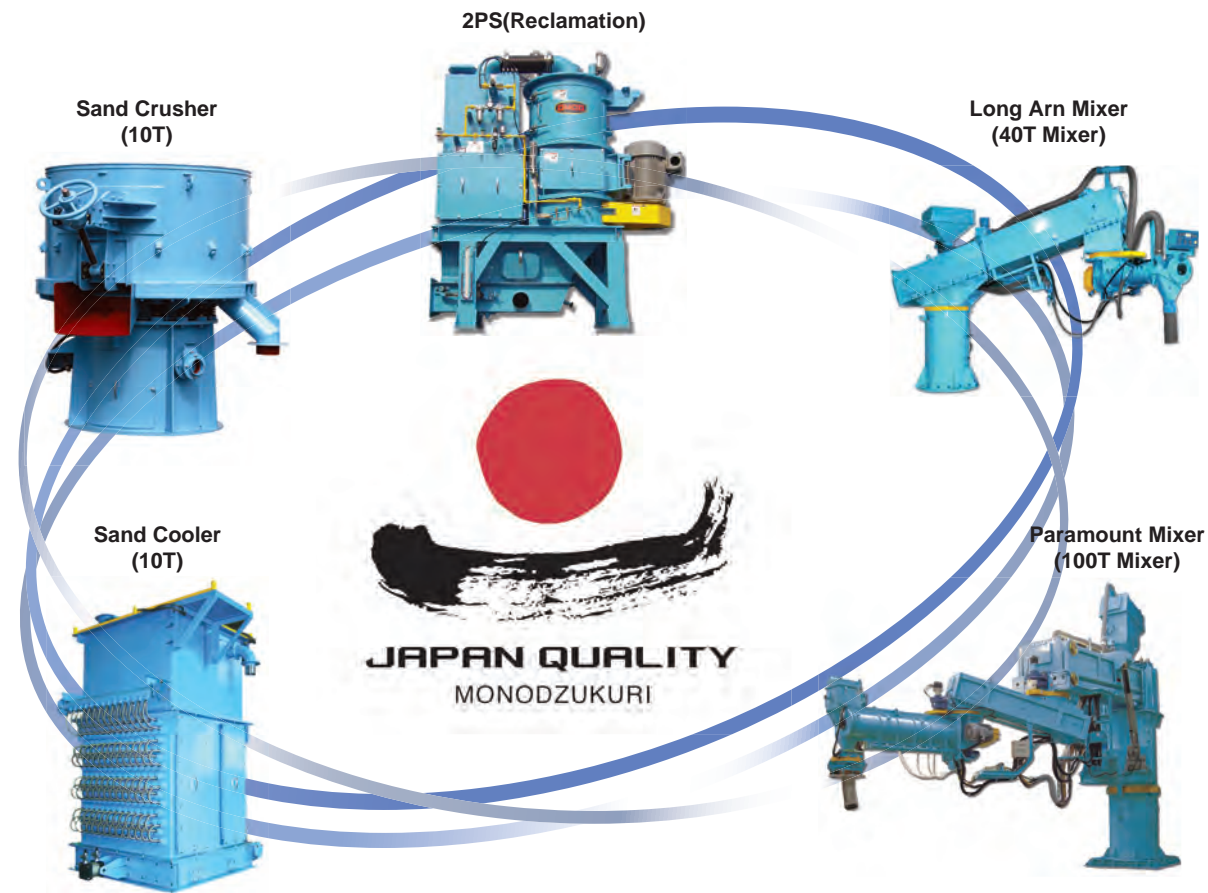

Company	Taiyo Machinery Co., Ltd
Address	1-7, 4-Chome, Tsurumachi, Taisho-Ku, Osaka 551-0023 Japan
Tel	+81-6-6556-1601
Fax	+81-6-6556-1222
E-mail	info@omco-taiyo.co.jp
URL	http://www.omco-taiyo.co.jp



**TAIYO MACHINERY CO., LTD.**  
**太洋マシナリー株式会社**

## Standard Plant For No Bake Process

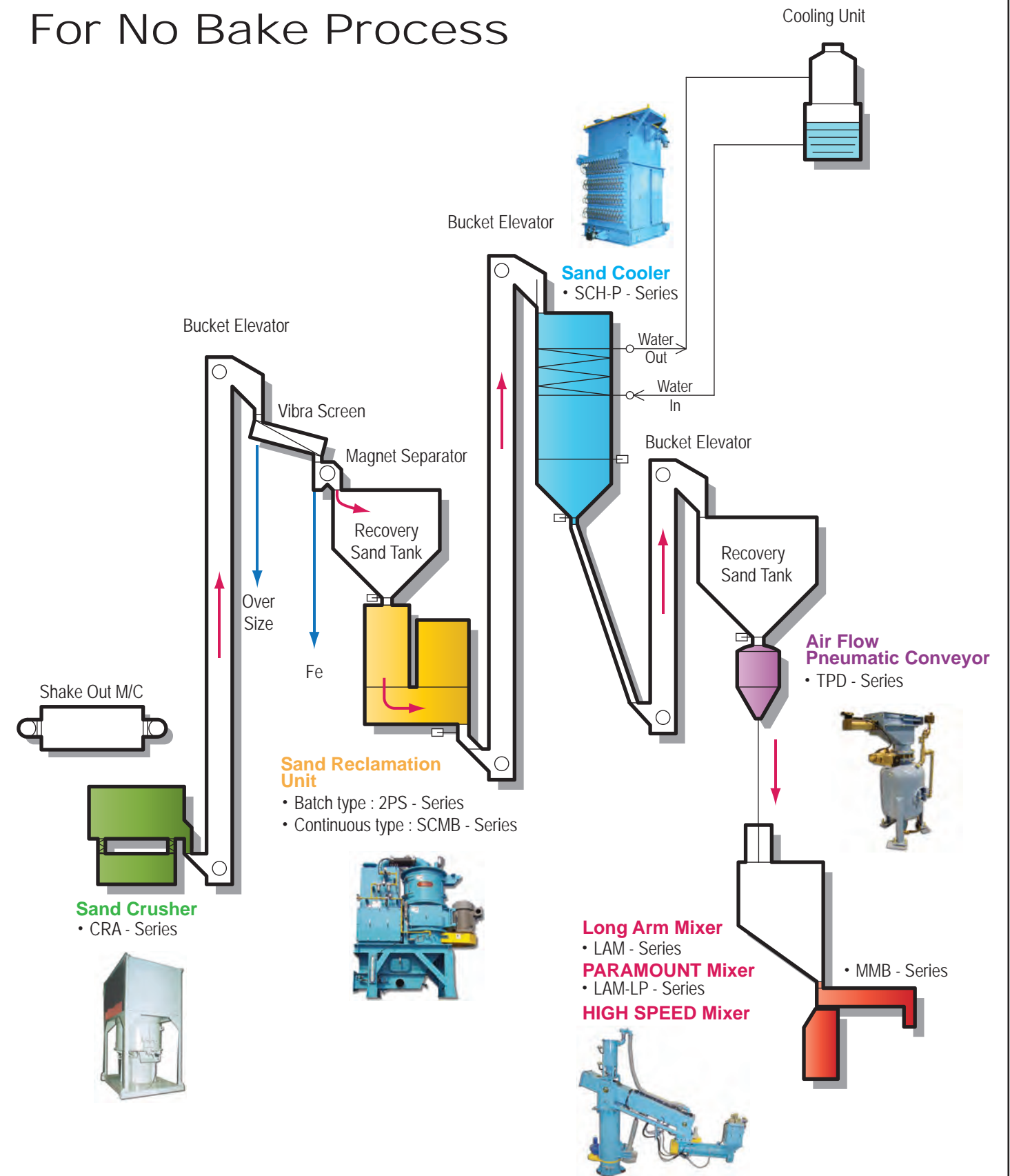

SAND LUMP BREAKER

CR-SERIES

# Shakeout Machine

# Sand Crusher

It is the most suitable for the preprocessing of sand reclamation of no bake casting.

**Achieved 110 tons of load weight (the world's largest)**

### Comparisons of single mass and two-mass systems

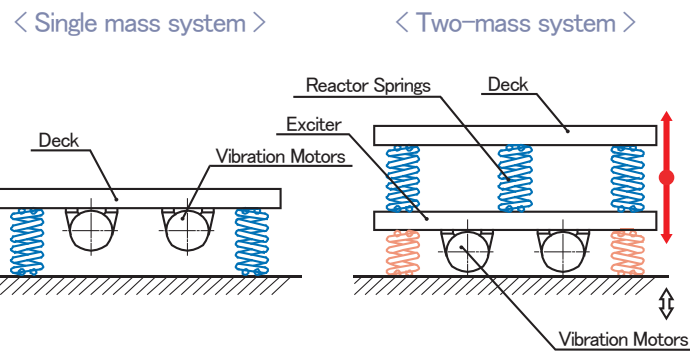

	Single mass system	Two-mass system
Type of Vibration	Brute force system	Sub-resonant tuned system
Energy Consumption	Large	Small (About 1/2)
Transmittance of Vibration to ground	Large (Directly transmitted)	Small (Isolation structure)
Bounce at start-up and shutdown	Large (Passing through the frequency of resonance)	Small (Setting with below the frequency of resonance)



### Outlines and Specifications

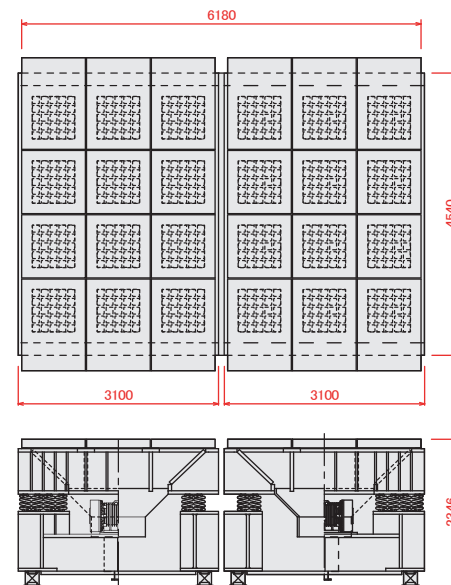

Type	2VS3145 × 2sets
Dimensions	W:3100 L:4540 H:2346
Stroke (Shakeout Body)	5~7mm
Stroke (Exciter)	8~11mm
Rotation	About 880rpm
Motor	15kw × 8P × 2motors × 2
Static Load	About 104tons × 2sets (including material load)
Dynamic Load	Vertically about ±9600kgf × 2sets

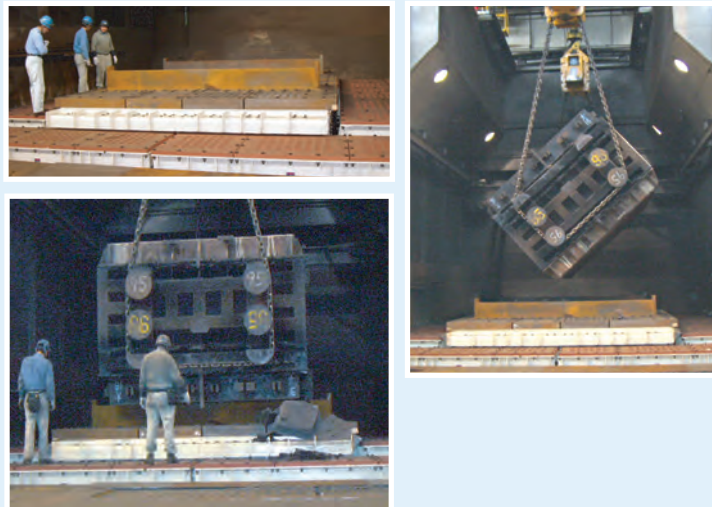

Installed at Omeazaki Foundry of Kimura Chuzosho Co., Ltd.

### Features

- Uniformly-sized sand grains
  - A unique vibratory motion of the sand crusher makes the sand lumps rub each other, break into small pieces, and granulates. And also it gets rid of the binder adhering rigidly on the surface of sand grains.
- Structure for wear resistance
  - There are less wear parts and the maintenance is easier than other crushers because of its unique gyratory mechanism and round cell.
- Equipped with the discharge gate for foreign materials.
  - The machine failure doesn't occur even if foreign materials or metallic pieces enter in the machine with sand lump. The foreign materials and metals are easily removed from the discharge gate to outside.
- Large sand lump can be processed.
  - Sand lump and sand after demolding process can be fed by a belt conveyor or shovel loader. Large sand lump can be also processed directly.



### Specification and dimensions

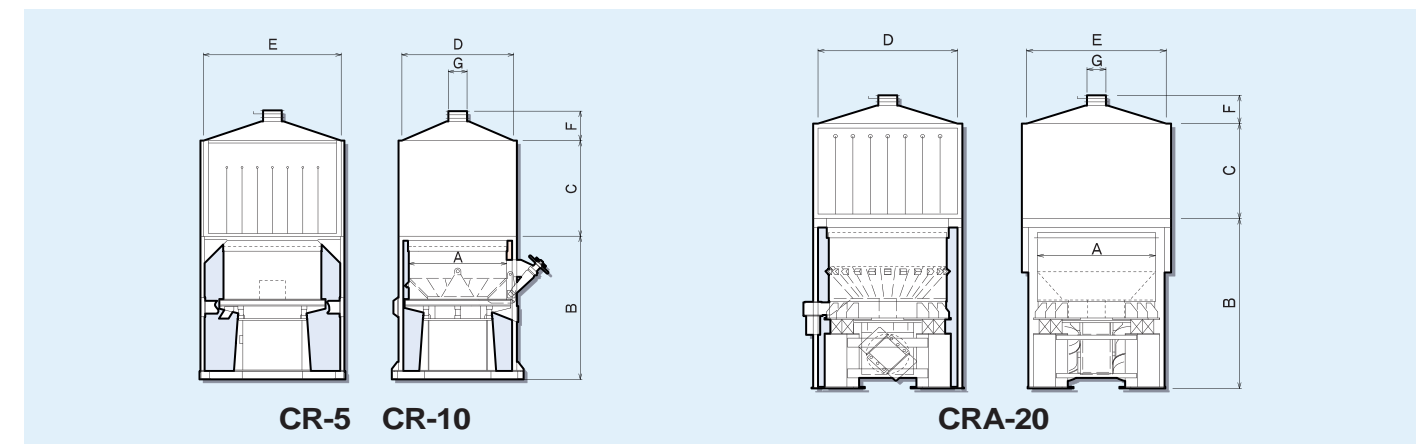

Model	CR-5	CR-10	CR-20
Capacity (T/Hr)	5	10	20
Motor (kw)	3.7	7.5	7.5 × 2
A (φ)	1280	1530	1800
B (mm)	1890	2231	2835
C (mm)	1219	1500	1550
D (mm)	1524	1850	2300
E (mm)	2000	2250	2300
F (mm)	350	350	455
G (φ)	190	291	340

SAND RECLAMATION EQUIPMENT

2PS-SERIES

# 2-Pattern Shiner

Uniform reclamation by batch process

SAND RECLAMATION EQUIPMENT

SCM-SERIES

# Sand Shiner

Newly developed sand reclamation system with high recycle rate!



Features

- High quality of sand reclamation and recycle performance
  - It completely removes chemical binder from sand in a closed system.
  - Because the process time of reclamation can be adjusted freely according to the characteristics of sand, the reclaimed sand is supplied with stable and high quality.
  - Scrubbing style of reclamation in which the sand is rubbed together minimizes the breakage of sand grain and reclaims high quality of sand for molding.
- Equipped with fluidized bed separator for fines
  - In the fluidized bed separator under the reclamation part, fines are removed and the sand is cooled down.
  - The grain size distribution can be controlled by adjusting the air blow volume. (Numerical control by manometer)
- Excellent maintenance productivity
- It matches all needs for sand reclamation

Uniform reclamation

In the reclamation process, the ring hood is lowered and the reclamation part is closed. When the reclamation process is done, the ring hood is lifted up and the sand is discharged. The sand poured is reclaimed uniformly by such the batch process.

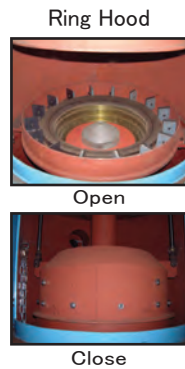

High performance fines separator

After the reclamation process, sand and fines are classified in the fluidized bed separator. Air is blown into the fluidized bed by the blower and the sand and fines are fluidized. Then fines are extracted by the dust collector. The classification of sand and fines can be easily adjusted by the air volume from the blower or to the dust collector

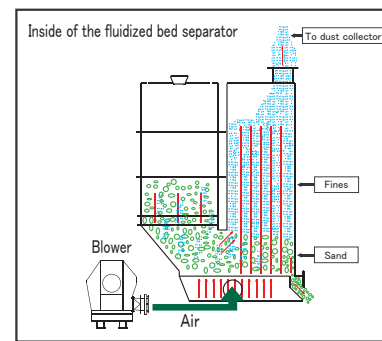

Specification and dimensions

Model	2PS-15	2PS-22	2PS-30	2PS-45
Moter (kw)	15	22	30	45
Batch weight (kg)	25 ~ 40	25 ~ 40	25 ~ 40	30 ~ 80

Utility

Model	2PS-15	2PS-22	2PS-30	2PS-45
Electrical power (kw) ※	18.7	25.7	33.7	48.7
Compressed air (Nm3/min)	0.2	0.2	0.2	0.2
Ducting air volume (m3/min)	40	40	40	40

※ The electrical power includes the blower.

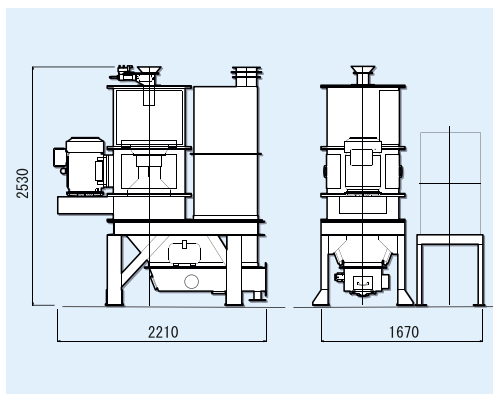

Note: It is subject to change the details in this catalog without notice.

Features

- High quality of sand reclamation and recycle performance
  - Scrubbing style of reclamation in which the sand is rubbed together minimizes the breakage of sand grain and reclaims high quality of sand for molding
  - Because the process time of reclamation can be adjusted freely according to the characteristics of sand, the reclaimed sand is supplied with stable and high quality.
  - The continuous reclamation system can reclaim a large quantity of sand, maximum 15 ton/h.
  - The reclamation part can be piled up so that the reclamation process can be increased.
- Equipped with fluidized bed separator for fines
  - In the fluidized bed separator under the reclamation part, fines are removed and the sand is cooled down.
  - The grain size distribution can be controlled by adjusting the air blow volume. (Numerical control by manometer)
- Excellent maintenance productivity
- It matches all needs for sand reclamation



Continuous reclamation system

- By adjusting a slide plate according to the type of sand and binder process, the ignition loss rate can be changed.
- The sand is reclaimed appropriately according to the type of sand and casting process by inverter control. (Option)

High performance fines separator

After the reclamation process, sand and fines are classified in the fluidized bed separator. Air is blown into the fluidized bed by the blower and the sand and fines are fluidized. Then fines are extracted by the dust collector. The classification of sand and fines can be easily adjusted by the air volume from the blower or to the dust collector

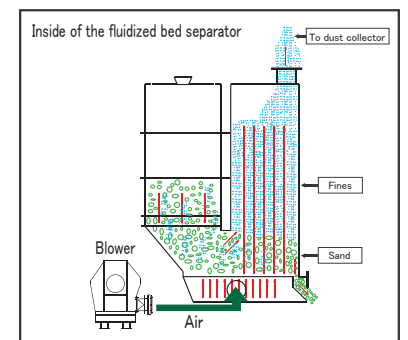

Specification and dimensions

Model	SCMB-22	SCMB-30	SCMB-45
Capacity (T/Hr)	5	10	15
Reclamation motor (kg)	22	30	45
Blower motor (Nm3/min)	3.7	3.7	3.7
Ducting air volume (m3/min)	60	60	60

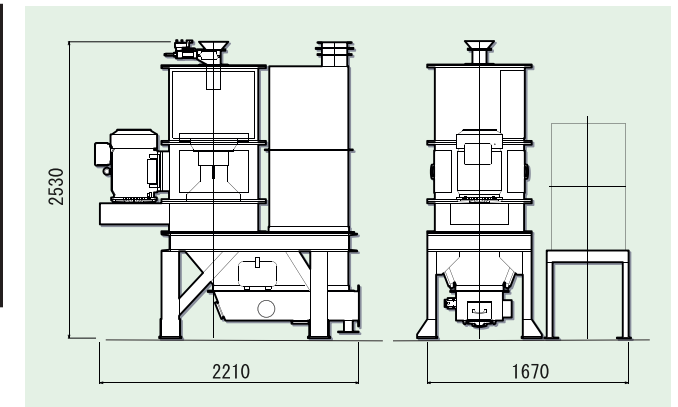

Note: It is subject to change the details in this catalog without notice.

SANDCOOLER FOR NO-BAKE

**SCH-P-SERIES**

BATCH MIXER

**MS-SERIES**

# Sand Cooler

Highly efficient cooler for dry sand

# Super Mixer

Excellent performance for mixing of any powder



### Features

- Improved sand cooling performance
  - The Sand Cooler performs highly efficient heat exchange by adopting pipe reducers to eliminate airlock in the pipe.
  - The heat can be exchanged smoothly in the array of piping considering sand characteristics.
  - The sand is cooled down uniformly by the flow uniforming gate.
  - It adopts the programmable control to measure the sand temperature accurately.
  - The cooling capacity is maintained by opening the primary water valve when the temperature of the circulation water rises.
- Excellent maintenance productivity.
- Design to meet the customer's usage
  - The number of the cooling unit is determined according to the condition of sand cooling, installation space and performance.

### Specification and Dimensions

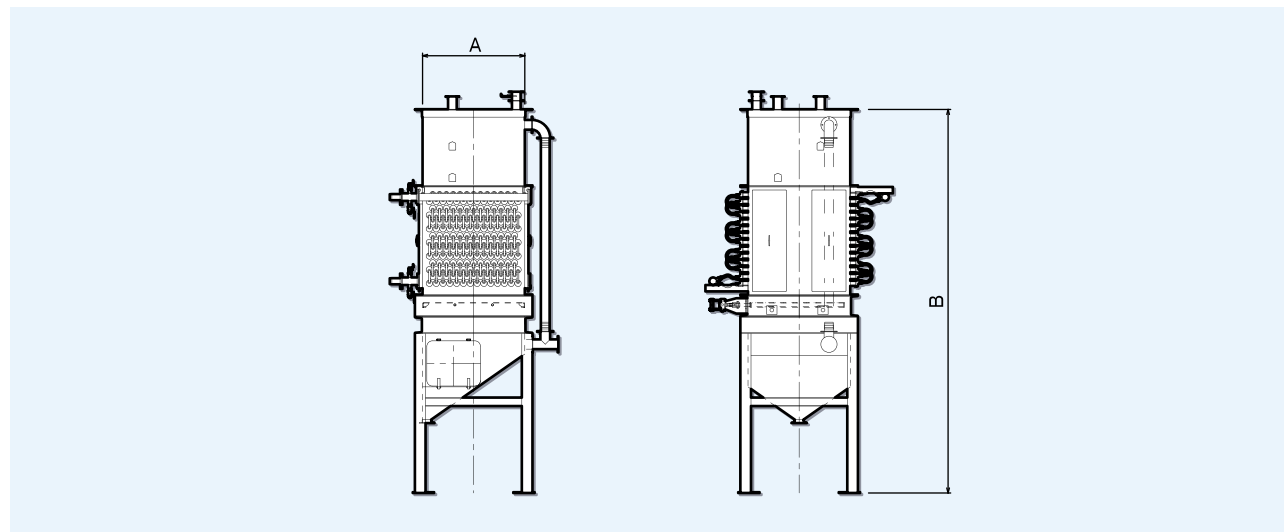

Model	SCH-3P	SCH-5P	SCH-10P	SCH-20P
Sand cooling temperature	80 ⇒ 35°C (Standard setting)			
Capacity (ton/hr)	3	5	10	20
Motor (kw)	1.5 + 0.2	2.2 + 0.3	3.7 + 0.75	7.5 + 1.5
A (mm)	□1200	□1200	□1500	□1800
B (mm)	3840	4320	5740	6240

Note: It is subject to change the details in this catalog without notice.



### Features

- Excellent mixing performance.
  - It equips with the rotary impellor which three-dimensionally mixes the sand and spherical bowl.
  - The mixing speed can be adjusted according to the type of sand and binder.
- High operability.
  - It fits in any plants because of its compact size.
  - It is suitable to mix many types of sand or powder.
  - Measuring of mixing material can be done automatically.
- High maintenance productivity.
  - It equips with the self-cleaning program to prevent the sand from adhering inside the bowl.
  - The mixing part is of pullout mechanism for easy maintenance.
- It matches all needs for sand mixing.

### Specification and dimensions

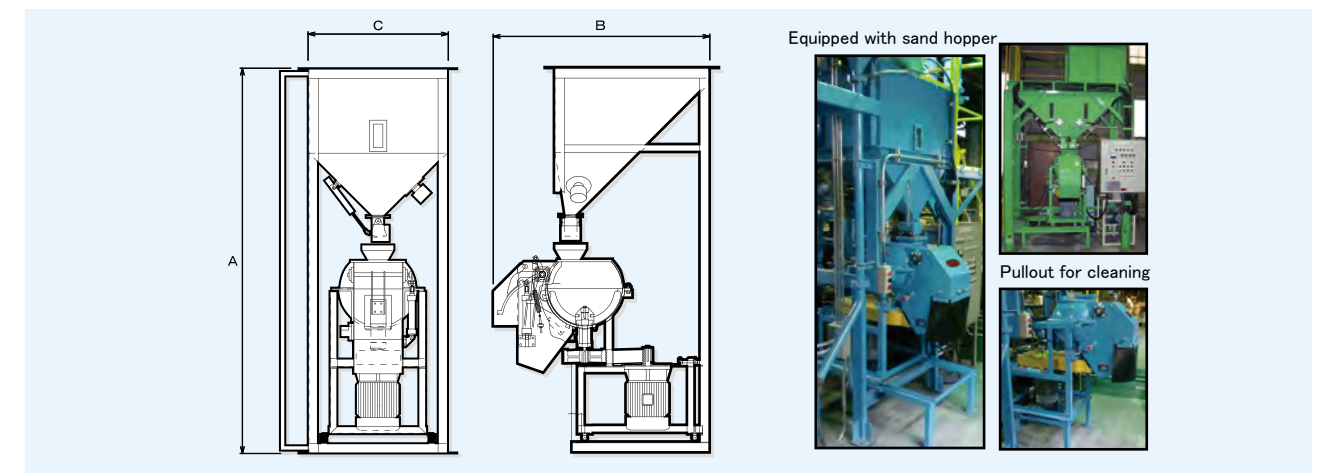

Model	MS- I	MS- II
Mixing capacity (kg/B)	30	100
Mixing time (sec)	30 ~ 40	45 ~ 55
Mixer motor (kw)	5.5	11
Sand tank (L)	250	400
A (mm)	2450	3150
B (mm)	1370	1725
C (mm)	915	1400

Note: It is subject to change the details in this catalog without notice.

CONTINUOUS MIXER

MMB-SERIES

# High Speed mixer

Optimum and economical speed for mixing has been pursued!



Features

- It is suitable for small and medium size of moldings and cores.
  - It fits in any plants because of its compact size.
  - The mixing speed can be adjusted according to the type of sand and binder.
- High operability.
  - The amount of binder to be fed can be adjusted in 3 steps.
  - Measuring of binder and sand can be done automatically.
- High maintenance productivity.
  - Inspection doors on both sides are added to the option to shorten cleaning time of trough.
  - Pumps, solenoid valves, and piping are installed on the side of the machine for easy maintenance.
- It matches all needs for sand mixing.

Specification and dimensions

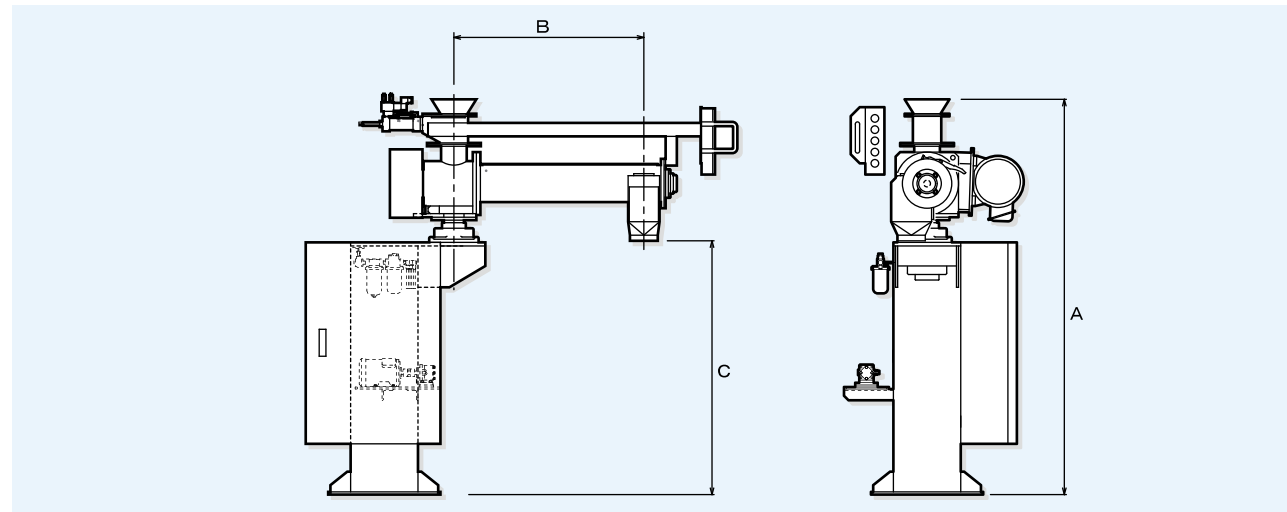

Model	MMB-5	MMB-10	MMB-20
Mixing capacity (T/Hr)	3 ~ 5	5 ~ 10	10 ~ 20
Mixing time (kg/min)	50 ~ 83	83 ~ 166	166 ~ 333
Mixer motor (kw)	3.7	5.5	11
A (mm)	1760	1750	2370
B (mm)	846	1038	1650
C (mm)	1130	1130	1650

Note: It is subject to change the details in this catalog without notice.

LAMB-SERIES

# Long Arm Mixer

The High Speed Mixing and Kneading Machine, Long Arm Mixer is applicable to wide range of work.



Features

- With a wide working area available, molding work can be centralized.
- Because the mixer is equipped at the tip of the slewing arm, molding can be made immediately after mixing, thus not being restricted by the allowable treating time.
- As mixing and kneading are made by the mixer at the tip, no area other than the mixed itself is required to be cleaned.

Specification and dimensions

Model	LAMB-5	LAMB-10	LAMB-20	LAMB-30	LAMB-40	LAMB-60
Mixing capacity (T/Hr)	3~5	5~10	10~20	15~30	20~40	30~60
Mixing capacity (kg/min)	50~83	83~166	166~333	250~500	333~666	500~1080
Mixer motor (kw)	3.7	5.5	11	15	19	30
A (mm)	1500 (S) 3000 (3L)		3000 (3L) 4000 (4L)		4000 (4L) 5000 (5L)	
B (mm)	846	1038	1652 (S) 2500 (L)	1730 (S) 2500 (L)	1935 (S) 3000 (L)	2140 (S) 3000 (L)

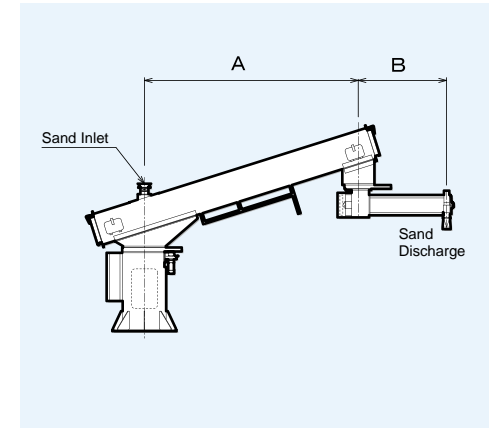

**Paramount mixer** Remote control, up and down mechanism, and the working range are wide, and it improves the quality.

- The LAMB-LP series is equipped with the going-up and down mechanism and the mixer part goes up and down.

Model	LAMB-10LP	LAMB-20LP	LAMB-30LP	LAMB-40LP	LAMB-60LP	LAMB-100LP
Mixing capacity (T/Hr)	3~5	10~20	15~30	20~40	30~60	40~100
Mixing capacity (kg/min)	50~83	166~333	250~500		500~1080	666~1666
Mixer motor (kw)	5.5	11	15	22	37	45
A (mm)	3000(L)	3000(S) 4000(L)		4000(S) 5000(L)		2500 5000
B (mm)	1038	1650	1730	3000		

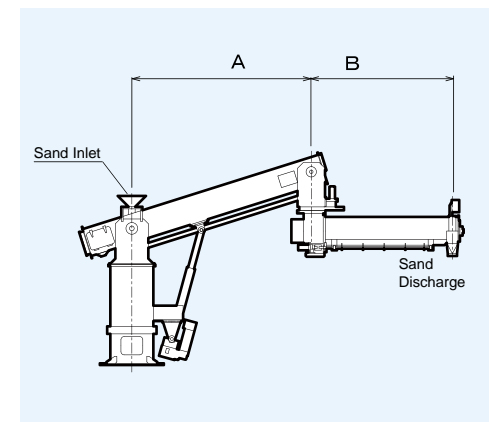

Note: It is subject to change the details in this catalog without notice.

**VT-SERIES**

# Vibrating Table

Most suitable vibrating table for no bake casting



**Features**

- I can make a uniform skin side in a short time by producing microvibration
- The most suitable filling power can occur from an accessory to a big game by a laser sensor and variableness-style weight automatically
- I can transmit microvibration surely by being equipped with an electromagnetic magnet
- I stop by large-scale brakes unit adoption instantly

**Standard Specifications**

Large load Type	Load	Max 100ton
	Power	33 Kw
	Acceleration	0.4~0.8G

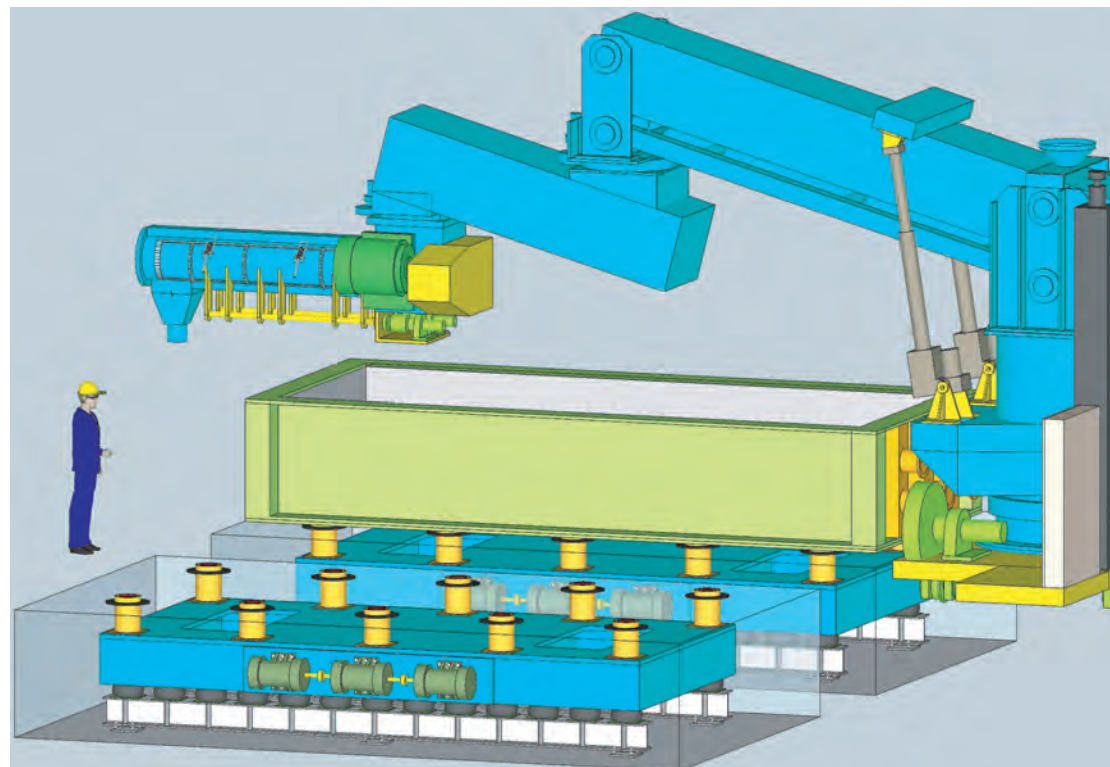

**MINIMINI-SERIES**

# Mini mini Super Mixer Type B

Perfect for Pocket sand and Small core... Easy mixing the small amount.



**Features**

- Excellent mixing performance.
  - We made the spiral blade and the spherical bowl. The sand moves three-dimensionally.
- No waste sand even it's the small amount.
  - Mix the proper amount of sand for pocket sand and small core.
- Desk-Size(Mobile easily with handle)
  - Power-200V or 100V power plug.

**General Drawing**

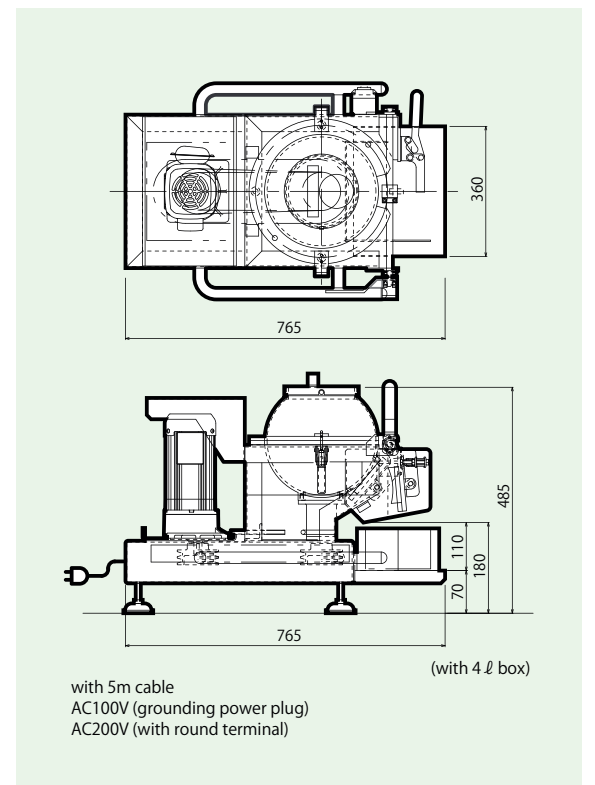

**Specification**

Model	MMS-004 (Mini-batch type)
Capacity	4kg/B
Voltage	<B1>AC100V 50/60Hz <B2>AC200V 50/60Hz
Operation	ON-OFF 2point
Weight	≒ 70kg
Power	0.4kW
Rated current	6.9/6.0A (50/60Hz)

※Mixing capacity depends on the process.

MINIMINI-SERIES

# Mini mini Air Vibrating Table

Perfect Vibrating for making no-bake core.



Features

- Compact design. (specialized for small no-bake core)
- Less noise and no big shake when starting and stopping.
- Vibrating force changeable by adjusting air pressure and exhaust air volume.

Specification

Table size	□500mm × 350H
Max.load	2 models
	1. AVT0505-005 50kg
	2. AVT0505-010 100kg
	• Air vibrator 1unit
	• Foot valve (ON-OFF)
	• With adjuster Valve for exhausting

General Drawing

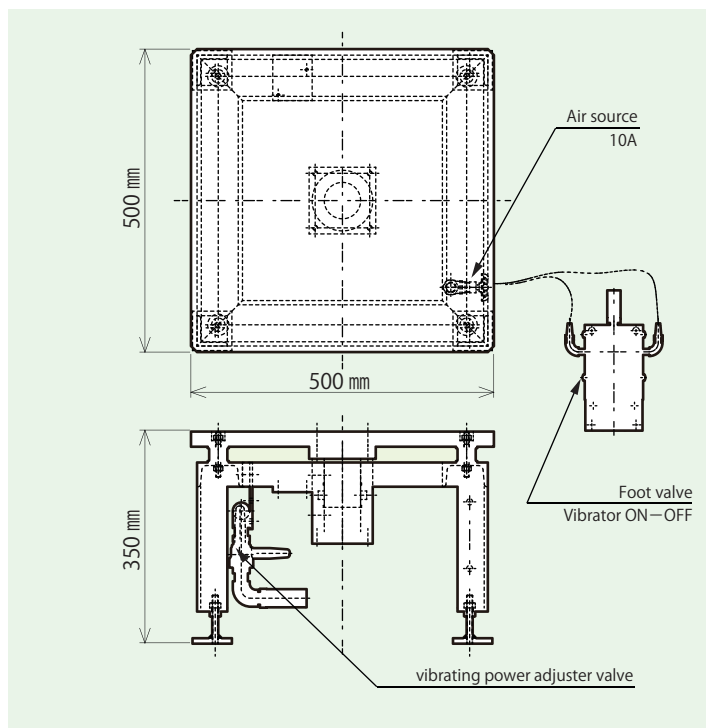

MINIMINI-SERIES

# Mini mini Crusher

Efficient collection of the usable sand from the small lump sand.



Features

- Perfect for recovery sand like the poor core and the residue from molding and cleaning.
- Compact design,space-saving,and mobile easily.
- Easy operation-Just turn ON-OFF.
- Cleaning the residue and iron pieces after collection of the usable from the inspection doors.

Specification

Model	MNCR-15
External dimensions	Casing □250x800H
Capacity	3~30kg/Hr
Volume of hopper	12L
Input	0.13kw x 4P
Control panel	ON-OFF 2 point
Power	AC220V/60Hz or AC200V/50Hz
Weight	≒ 110kg

※Processing capacity depends on the process.

General Drawing

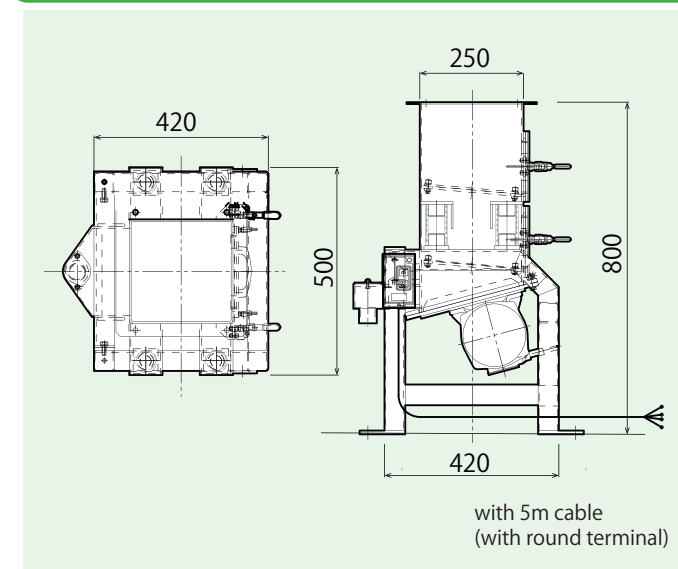



## Overseas Network

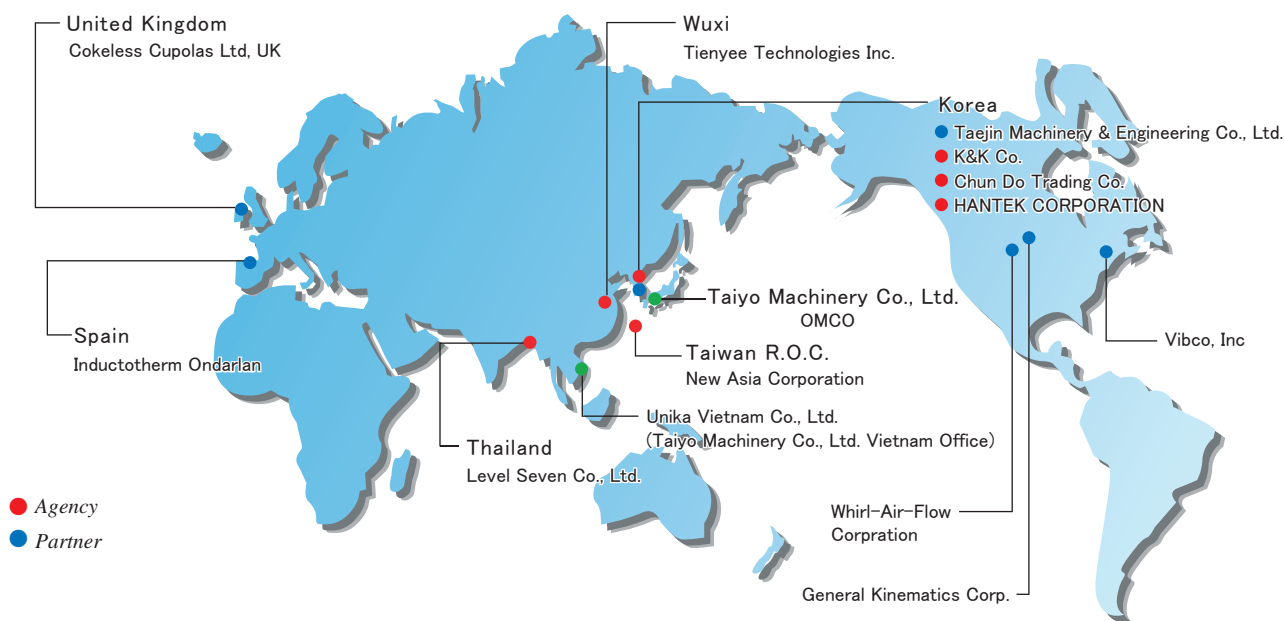

## OMCO Group

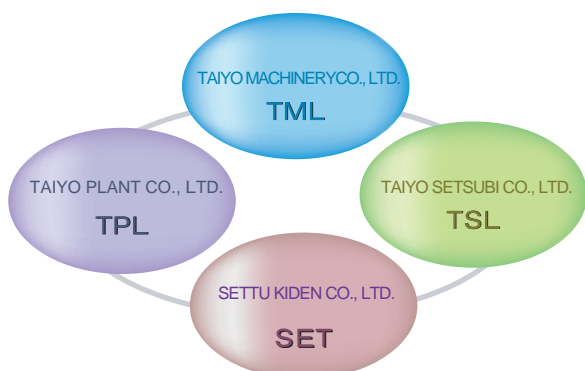

### TAIYO PLANT CO., LTD.

Fukuoka 1086-5, Nijo Masue, Itoshima-City, Fukuoka 819-1613 Japan  
Factory Tel : +81-92-325-1201 Fax : +81-92-325-1990

### TAIYO SETSUBI CO., LTD.

Osaka 18-43, 2-Chome, Mikuni Honmachi, Yodogawa-Ku, Osaka 532-0005 Japan  
Tel : +81-6-6394-1541 Fax : +81-6-6394-1543  
Kanto 12-8, 4-Chome, Yahei, Kawaguchi-City, Saitama 332-0002 Japan  
Tel : +81-48-224-8193 Fax : +81-48-223-3870  
Nagoya 412, 2-Chome, Fushiya, Nakagawa-Ku, Nagoya-City, Aich 454-0996 Japan  
Tel : +81-52-618-6620 Fax : +81-52-303-1582

### SETTSU KIDEN CO., LTD.

1-3, 1-Chome, Karasaki Minami, Takatsuki-City, Osaka 569-0833 Japan  
Tel : +81-72-677-4004 Fax : +81-72-677-4012

## Address

### ● Head Quarter

1-7, 4-Chome, Tsurumachi, Taisho-Ku, Osaka 551-0023 Japan  
Tel : +81-6-6556-1601 Fax : +81-6-6556-1222 E-mail : info@omco-taiyo.co.jp

### ● Osaka Branch

18-43, 2-Chome, Mikuni Honmachi, Yodogawa-Ku, Osaka 532-0005 Japan  
Tel : +81-6-6394-1101 Fax : +81-6-6394-0011 E-mail : osaka@omco-taiyo.co.jp

### ● Tokyo Branch

Buzenya Bldg. 3F, 1-9, 5-Chome, Shiba, Minato-Ku, Tokyo 108-0014 Japan  
Tel : +81-3-5445-2771 Fax : +81-3-5445-2775 E-mail : tokyo@omco-taiyo.co.jp

### ● Nagoya Branch

412, 2-Chome, Fushiya, Nakagawa-Ku, Nagoya-City, Aichi 454-0996 Japan  
Tel : +81-52-301-2611 Fax : +81-52-301-2622 E-mail : nagoya@omco-taiyo.co.jp

### ● Hiroshima Branch

8-25, Yokogawa Shinmachi, Nishi-Ku, Hiroshima-City, Hiroshima 733-0013 Japan  
Tel : +81-82-292-1966 Fax : +81-82-291-1391 E-mail : hiroshima@omco-taiyo.co.jp

## Access Map

